

MC68176

Advance Information MC68176 2-BIT A/D CONVERTER IC

The MC68176 chip is part of a total solution available from Motorola for providing FLEX™ paging capabilities in a low-power, low-cost system. Working in conjunction with any of several standard paging receivers, the MC68176 takes the 4-level baseband audio signals from the receiver and performs 8-bit DAC peak and valley detection, passing the digitized signal directly to the MC68175 FLEX™ chip for further decoding and FLEX protocol handling. Received messages are then passed to the host microcontroller or microprocessor via the Serial Peripheral Interface (SPI). The host processor (running FLEXstack™ software) interprets the data appropriately (as binary, alphanumeric or numeric message types), and handles all I/O and user interaction functions.

The FLEX paging protocol is a multi-speed, high-performance protocol adopted by leading service providers worldwide. FLEX protocol gives service providers the increased capacity, added reliability, and enhanced pager battery performance they need today. It also provides an upward migration path to the service provider which is completely transparent to the end user.

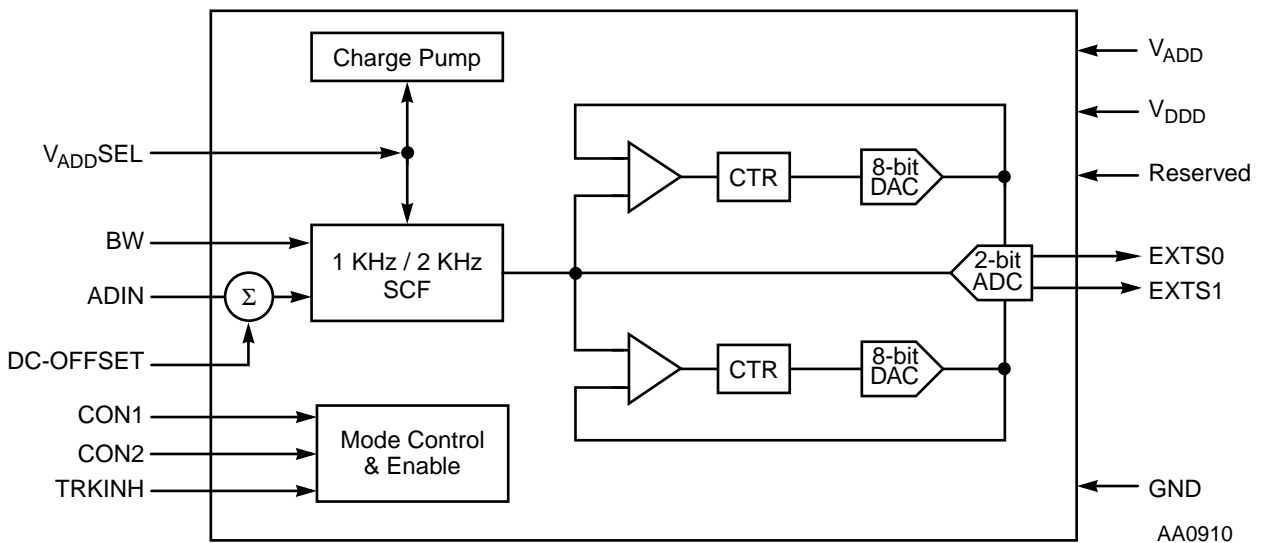

Figure 1 MC68176 Functional Block Diagram

This document contains information on a new product. Specifications and information herein are subject to change without notice.

MC68176 FEATURES

- Supports FLEX paging protocol with the MC68175 FLEX™ chip decoder IC
- 8-bit DAC peak and valley detectors
- Pin-selectable 2-pole Butterworth low pass filter:
 - BW = 0: 1 KHz \pm 5% (-3dB)
 - BW = 1: 2 KHz \pm 5% (-3dB)
- 2-bit A/D Converter
- 2 V and 3 V operation, \pm 10%, for both V_{DDD} and V_{ADD} .
- Flexible Supply mode; V_{ADD} and V_{DDD} may use any combination of supply voltages
- For $V_{ADD} = 2$ V, a charge pump supplies portions of the analog circuit with 3 V
- 600 mV_{p-p} input voltage range
- - 30 °C to + 85 °C operating temperature range
- 100 μ A typical operating current at $V_{ADD} = 2.7$ V
- Three modes of operation:
 - Fast Track mode—fast approximation to signal peak and valley in one cycle
 - Slow Track mode—precise peak and valley acquisition in five more cycles
 - Hold Acquisition
- Standby mode for low power consumption
- 14-pin SOIC package

MC68176 DESCRIPTION

The MC68176 is a 2-bit A/D Converter which converts a 4-level baseband audio signal to a 2-bit Gray scale code. The MC68176 is designed to interface with the MC68175 FLEX™ chip decoder IC, primarily for pager applications.

The MC68176 processes the input analog signal with a second-order Butterworth or Switched Capacitor filter of 1 KHz or 2 KHz cutoff frequency (depending on the baud rate of the incoming signal). The filtered signal is then passed to a peak and valley detector. The peak and valley detector uses two 8-bit Digital-to-Analog Converters (DACs), one for peak detection and one for valley detection. The outputs from the two DACs set the decoder reference voltages, V_{ref+} and V_{ref-} .

The adjustable dc offset allows the use of the MC68176 2-bit DAC with a wide range of receivers.

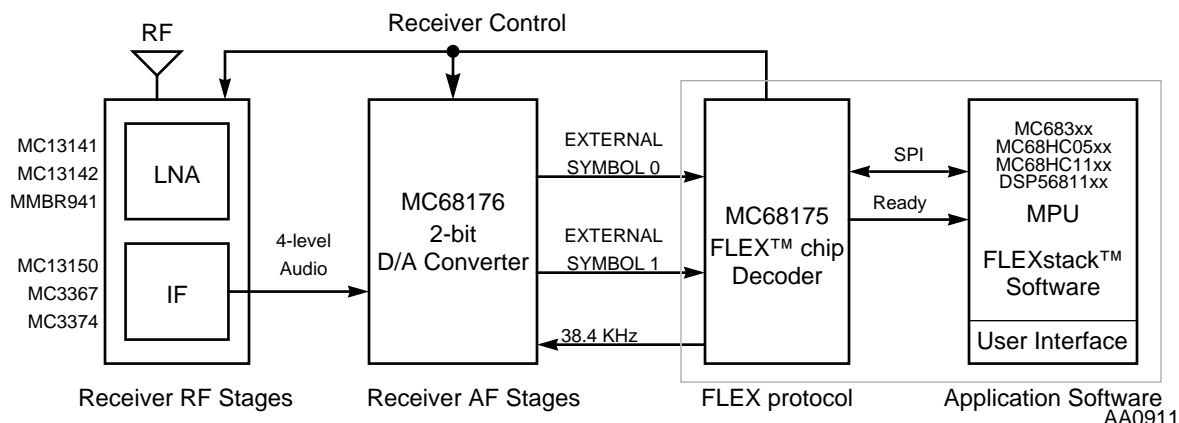

Figure 2 Typical FLEX Receiver System Block Diagram

FLEX PROTOCOL

FLEX paging protocol uses a synchronous time slot scheme, designed to increase the battery life of pagers. Instead of sending out messages at random, which requires the pager to be ready to receive messages at all times, all paging data for a particular pager is scheduled for a pre-defined time slot. This allows a FLEX pager to selectively decode one or more frames over the four-minute FLEX cycle, so the pager does not waste its battery life receiving and decoding data addressed to other pagers.

FLEX protocol offers the service provider a capacity increase of greater than ten times over a POCSAG 512 bps system. FLEX protocol supports three different speeds, allowing a system to run slowly initially, and increase speed as demand increases, while still using the same paging receivers without modification. FLEX protocol provides accurate message delivery by offering protection from fading conditions, such as bridges or overpasses. It provides 12 times the fading protection of POCSAG 1200, and 24 times that of POCSAG 2400.

FLEXstack SOFTWARE

FLEXstack™ system software from Motorola is a family of software components for building world-class products incorporating messaging capabilities. FLEXstack software is specifically designed to support the FLEX™ chip IC. It runs on a product's host processor and takes care of communicating with the FLEX™ chip IC and fully interpreting the code words passed between the FLEX™ chip and the host processor. The FLEXstack software and documentation may be downloaded from the Motorola website at <http://www.mot.com/SPS/FLEXstack>.

FLEX DEVELOPMENT

The MC68175FDB FLEX Development Board provides a convenient platform to test and develop a FLEX paging system. The board supports one or two MC68175 FLEX™ chips, a socket for an MC68176 2-bit D/A Converter, separate power connectors for 2 V and 3 V operation, numerous configuration options, and connectors for 4-level baseband audio input, RF receiver connection, and SPI port for connection to a host processor.

PRODUCT DOCUMENTATION

The manuals listed in **Table 1** are required for a complete description of the MC68176 and related products, and are necessary to design with the part properly. Documentation is available from a local Motorola distributor, Motorola semiconductor sales office, Motorola Literature Distribution Center, or the Motorola Wireless home page on the Internet, <http://www.motorola-dsp.com>. The FLEX page is <http://www.mot.com/SPS/FLEXchip>.

Table 1 Additional Documentation

Document Name	Description	Order Number
MC68176 Technical Data	MC68176 feature list, and physical, electrical, timing and packaging specifications	MC68176/D
MC68175 Technical Data	MC68175 feature list, and physical, electrical, timing and packaging specifications	MC68175/D
MC68175 Product Brief	MC68175 description and features	MC68175P/D
MC68175FDB User Manual	MC68175FDB feature list, specifications, configuration information, and development guidelines	MC68175FDBUM/AD

FLEX, FLEXstack, and Mfax are trademarks of Motorola, Inc.



Motorola reserves the right to make changes without further notice to any products herein. Motorola makes no warranty, representation or guarantee regarding the suitability of its products for any particular purpose, nor does Motorola assume any liability arising out of the application or use of any product or circuit, and specifically disclaims any and all liability, including without limitation consequential or incidental damages. "Typical" parameters which may be provided in Motorola data sheets and/or specifications can and do vary in different applications and actual performance may vary over time. All operating parameters, including "typicals" must be validated for each customer application by customer's technical experts. Motorola does not convey any license under its patent rights nor the rights of others. Motorola products are not designed, intended, or authorized for use as components in systems intended for surgical implant into the body, or other applications intended to support life, or for any other application in which the failure of the Motorola product could create a situation where personal injury or death may occur. Should Buyer purchase or use Motorola products for any such unintended or unauthorized application, Buyer shall indemnify and hold Motorola and its officers, employees, subsidiaries, affiliates, and distributors harmless against all claims, costs, damages, and expenses, and reasonable attorney fees arising out of, directly or indirectly, any claim of personal injury or death associated with such unintended or unauthorized use, even if such claim alleges that Motorola was negligent regarding the design or manufacture of the part. Motorola and  are registered trademarks of Motorola, Inc. Motorola, Inc. is an Equal Opportunity/Affirmative Action Employer.

How to reach us:

USA/Europe/Locations Not Listed:

Motorola Literature Distribution
P.O. Box 5405
Denver, Colorado 80217
1 (800) 441-2447
1 (303) 675-2140

Asia/Pacific:

Motorola Semiconductors H.K. Ltd.
8B Tai Ping Industrial Park
51 Ting Kok Road
Tai Po, N.T., Hong Kong
852-26629298

Japan:

Nippon Motorola Ltd.
Tatsumi-SPD-JLDC
6F Seibu-Butsuryu-Center
3-14-2 Tatsumi Koto-Ku
Tokyo 135, Japan
81-3-3521-8315

Technical Resource Center:

1 (800) 521-6274

Mfax™:

RMFAX0@email.sps.mot.com
TOUCHTONE (602) 244-6609

DSP Helpline

dsphelp@dsp.sps.mot.com

Internet:

<http://www.motorola-dsp.com>

