

Request For Quotation

Order the parts you need from our real-time inventory database. Simply complete a request for quotation form with your part information and a sales representative will respond to you with price and availability.

[Request For Quotation](#)

Your free datasheet starts on the next page.

More datasheets and data books are available from our homepage: <http://www.datasheetarchive.com>

SHINDENGEN

Schottky Rectifiers (SBD)

Single

D3FS4A

40V 2.6A

FEATURES

- Small SMT
- $T_j 150^{\circ}\text{C}$
- Low $V_F=0.45\text{V}$
- P_{RRSM} avalanche guaranteed

APPLICATION

- Switching power supply
- DC/DC converter
- Home Appliances, Office Equipment
- Telecommunication

OUTLINE DIMENSIONS

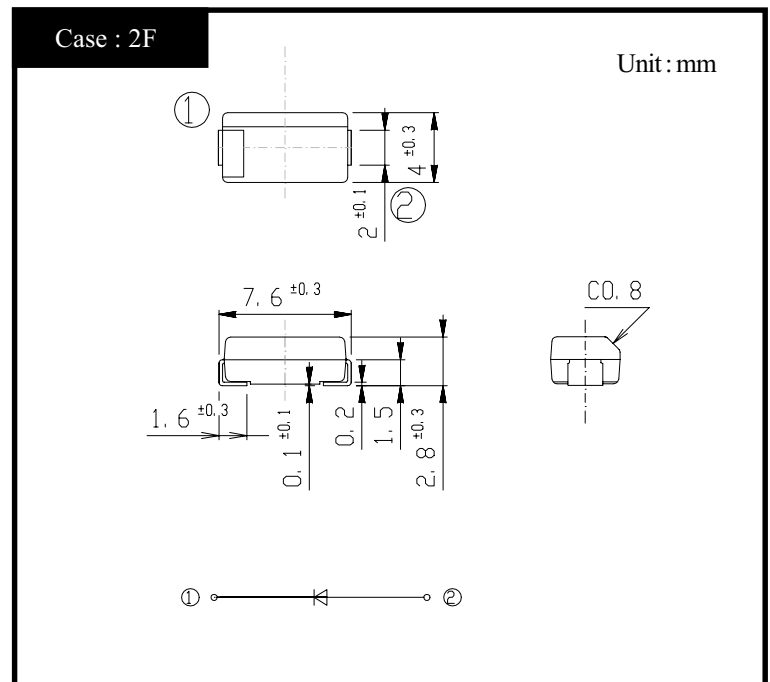

RATINGS

● Absolute Maximum Ratings (If not specified $T_I=25^{\circ}\text{C}$)

Item	Symbol	Conditions	Ratings	Unit
Storage Temperature	T_{stg}		-55~150	$^{\circ}\text{C}$
Operating Junction Temperature	T_j		150	$^{\circ}\text{C}$
Maximum Reverse Voltage	V_{RM}		40	V
Repetitive Peak Surge Reverse Voltage	V_{RRSM}	Pulse width 0.5ms, duty 1/40	45	V
Average Rectified Forward Current	I_O	50Hz sine wave, R-load $T_a=34^{\circ}\text{C}$ On alumina substrate	2.6	A
		50Hz sine wave, R-load $T_a=30^{\circ}\text{C}$ On glass-epoxy substrate	1.9	
Peak Surge Forward Current	I_{FSM}	50Hz sine wave, Non-repetitive 1 cycle peak value, $T_j=125^{\circ}\text{C}$	150	A
Repetitive Peak Surge Reverse Power	P_{RRSM}	Pulse width 10 μs , $T_j=25^{\circ}\text{C}$	330	W

● Electrical Characteristics (If not specified $T_I=25^{\circ}\text{C}$)

Item	Symbol	Conditions	Ratings	Unit
Forward Voltage	V_F	$I_F=2.6\text{A}$, Pulse measurement	Max.0.45	V
Reverse Current	I_R	$V_R=V_{RM}$, Pulse measurement	Max.5	mA
Junction Capacitance	C_j	$f=1\text{MHz}$, $V_R=10\text{V}$	Typ.340	pF
Thermal Resistance	θ_{jl}	junction to lead	Max.23	$^{\circ}\text{C}/\text{W}$
	θ_{ja}	junction to ambient On alumina substrate	Max.80	
		junction to ambient On glass-epoxy substrate	Max.115	

D3FS4A

Forward Voltage

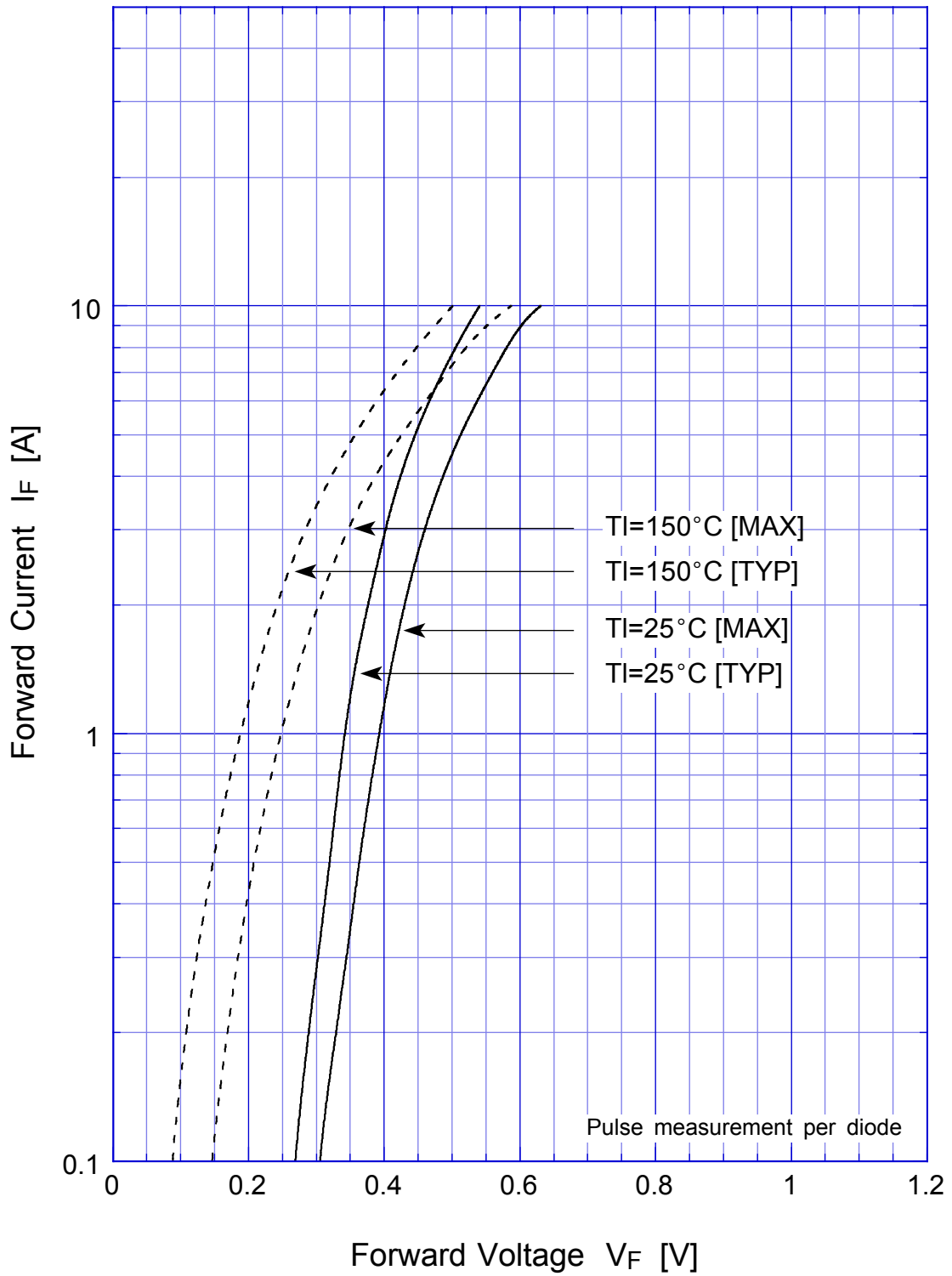

D3FS4A

Junction Capacitance

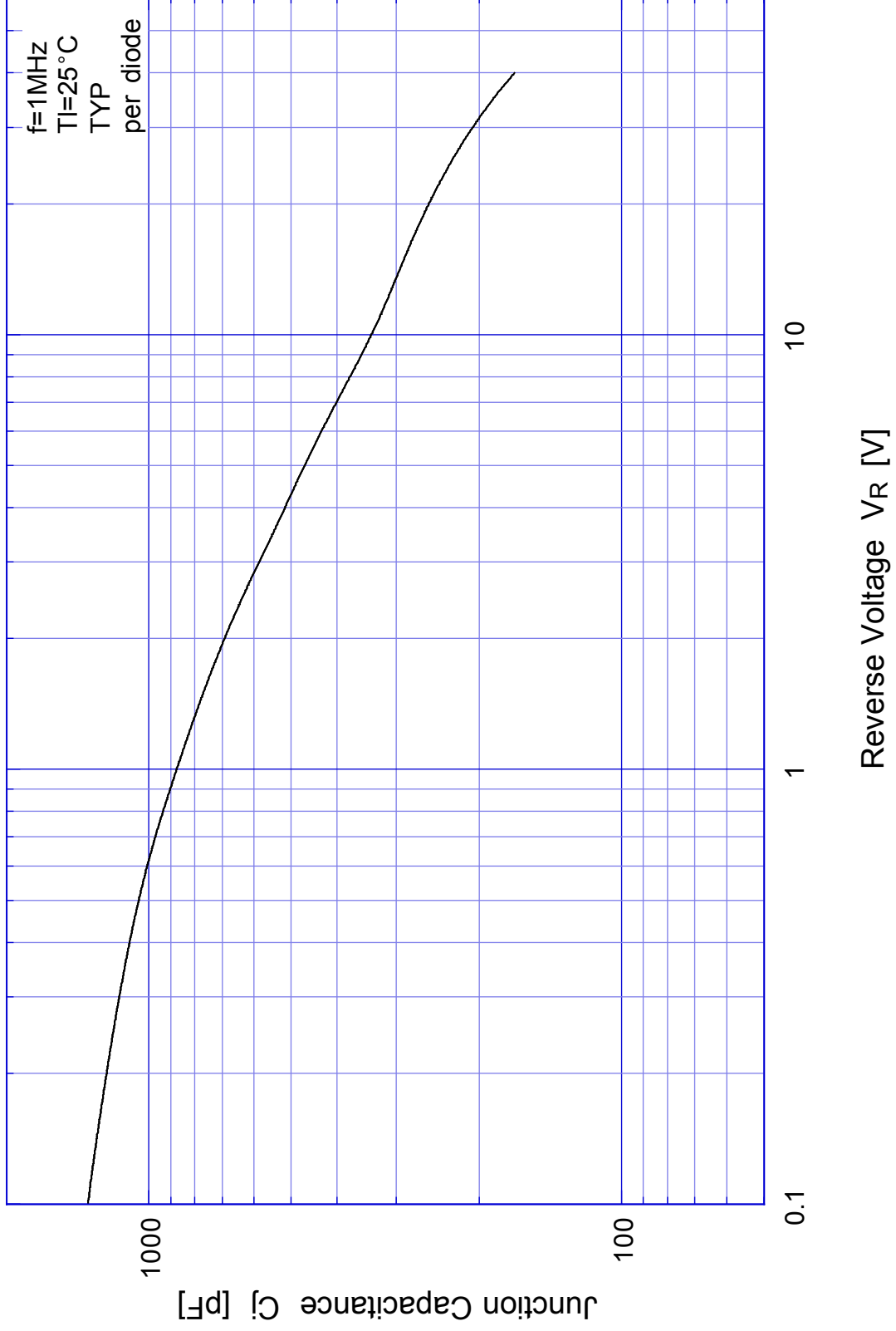

D3FS4A

Reverse Current

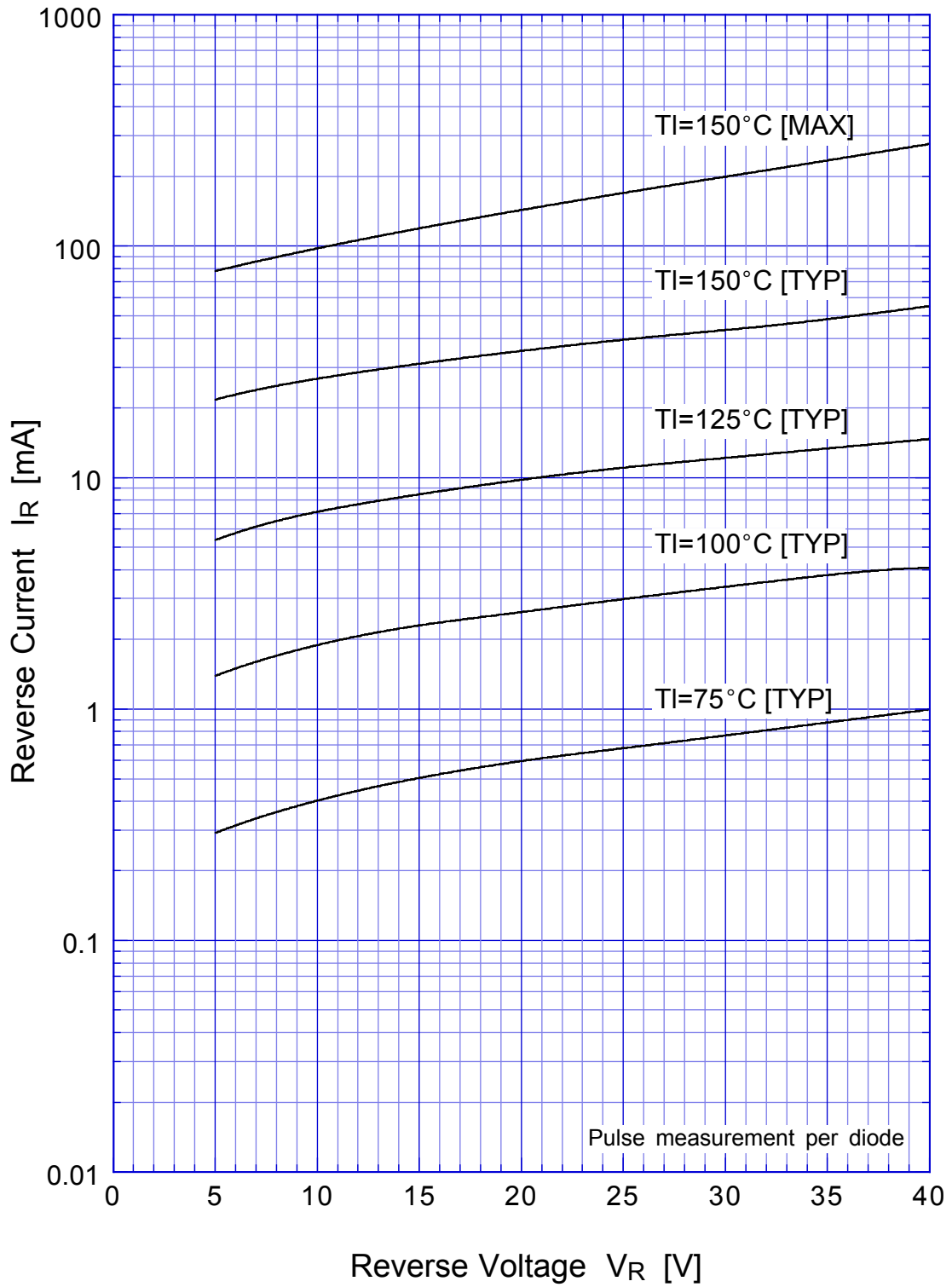

D3FS4A Reverse Power Dissipation

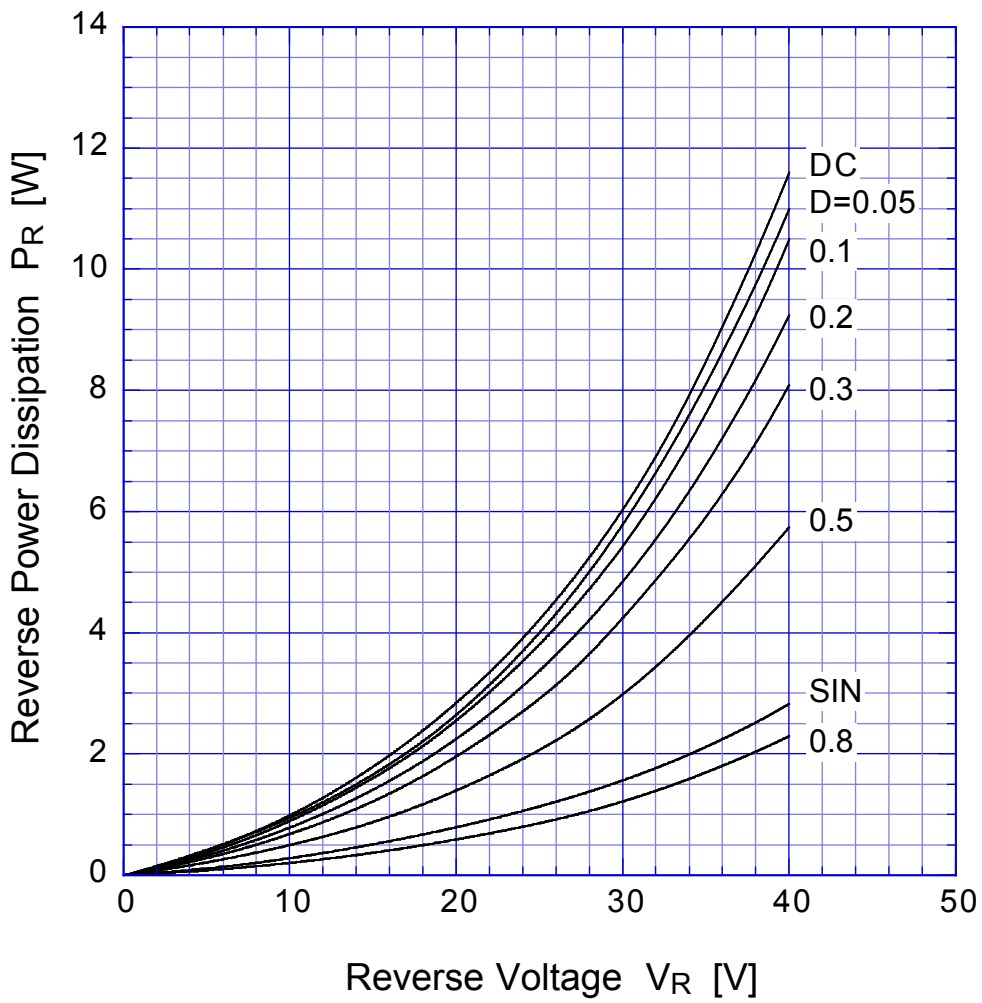

$T_j = 150^\circ\text{C}$

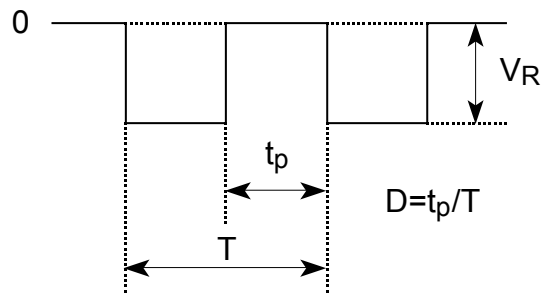

D3FS4A Forward Power Dissipation

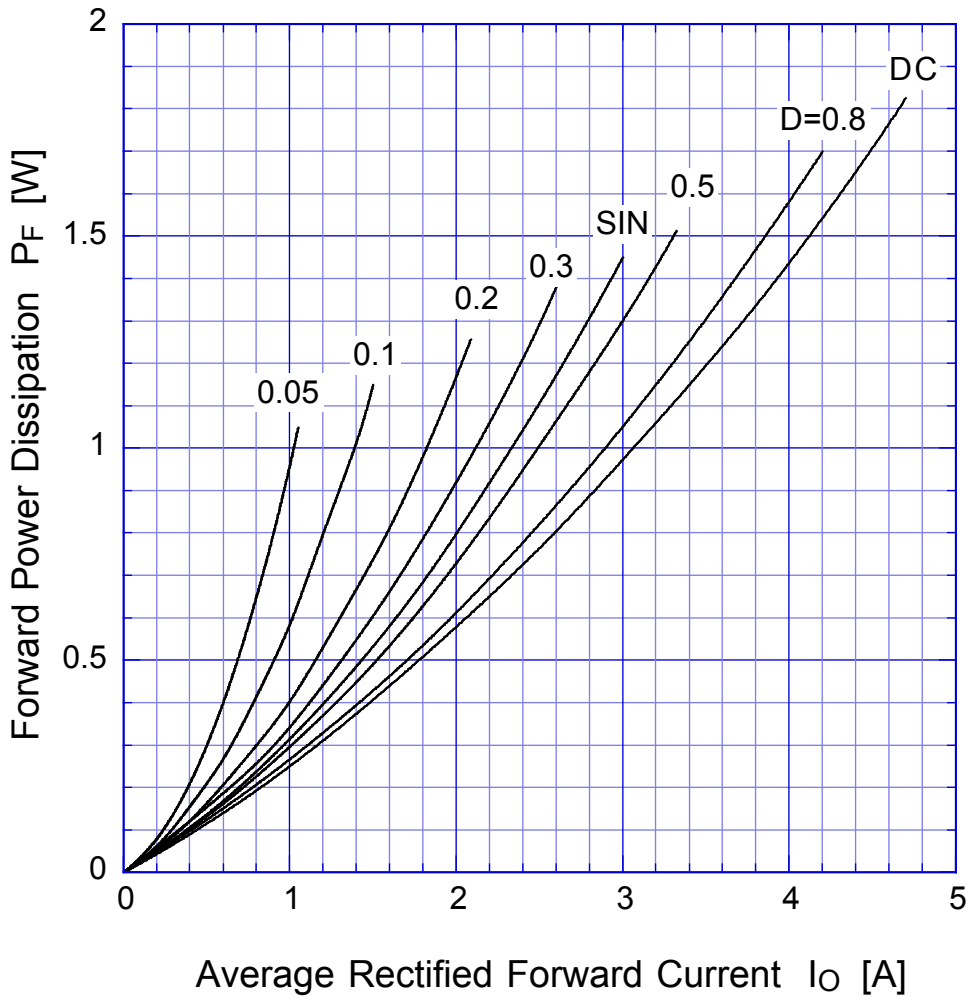

$T_j = 150^\circ\text{C}$

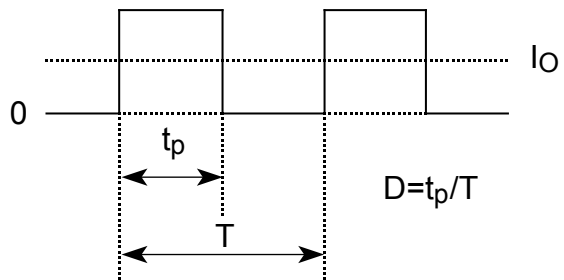

D3FS4A

Derating Curve

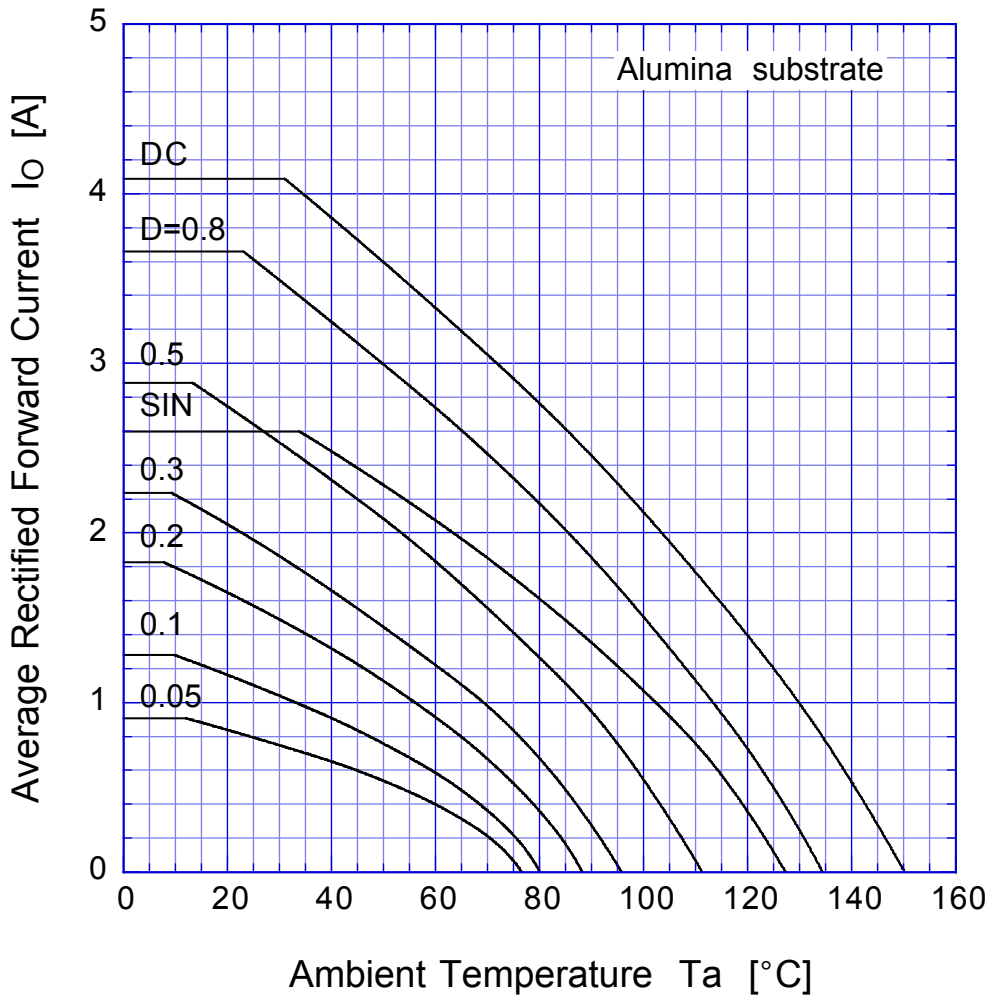

$V_R = 10V$



D3FS4A

Derating Curve

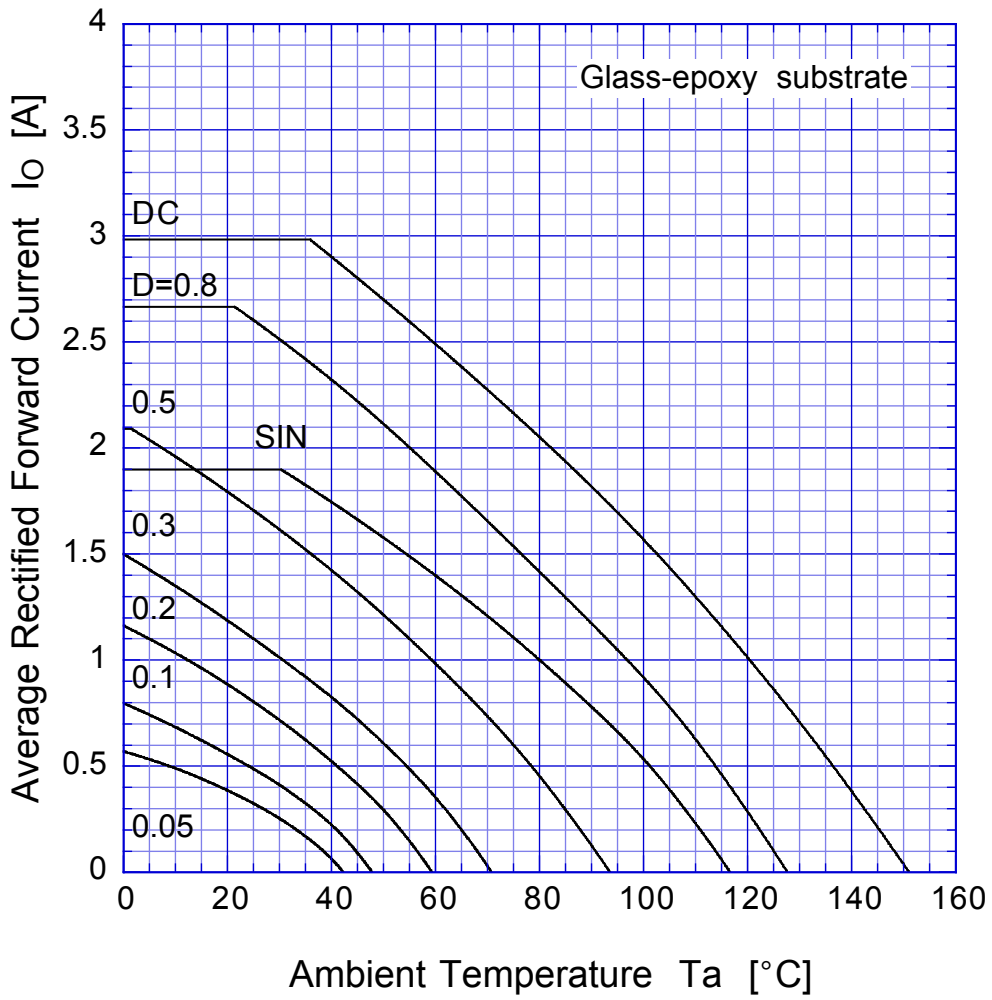

$V_R = 10V$

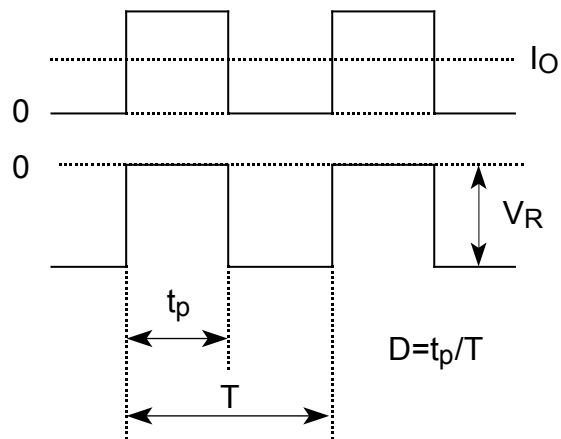

D3FS4A

Peak Surge Forward Capability

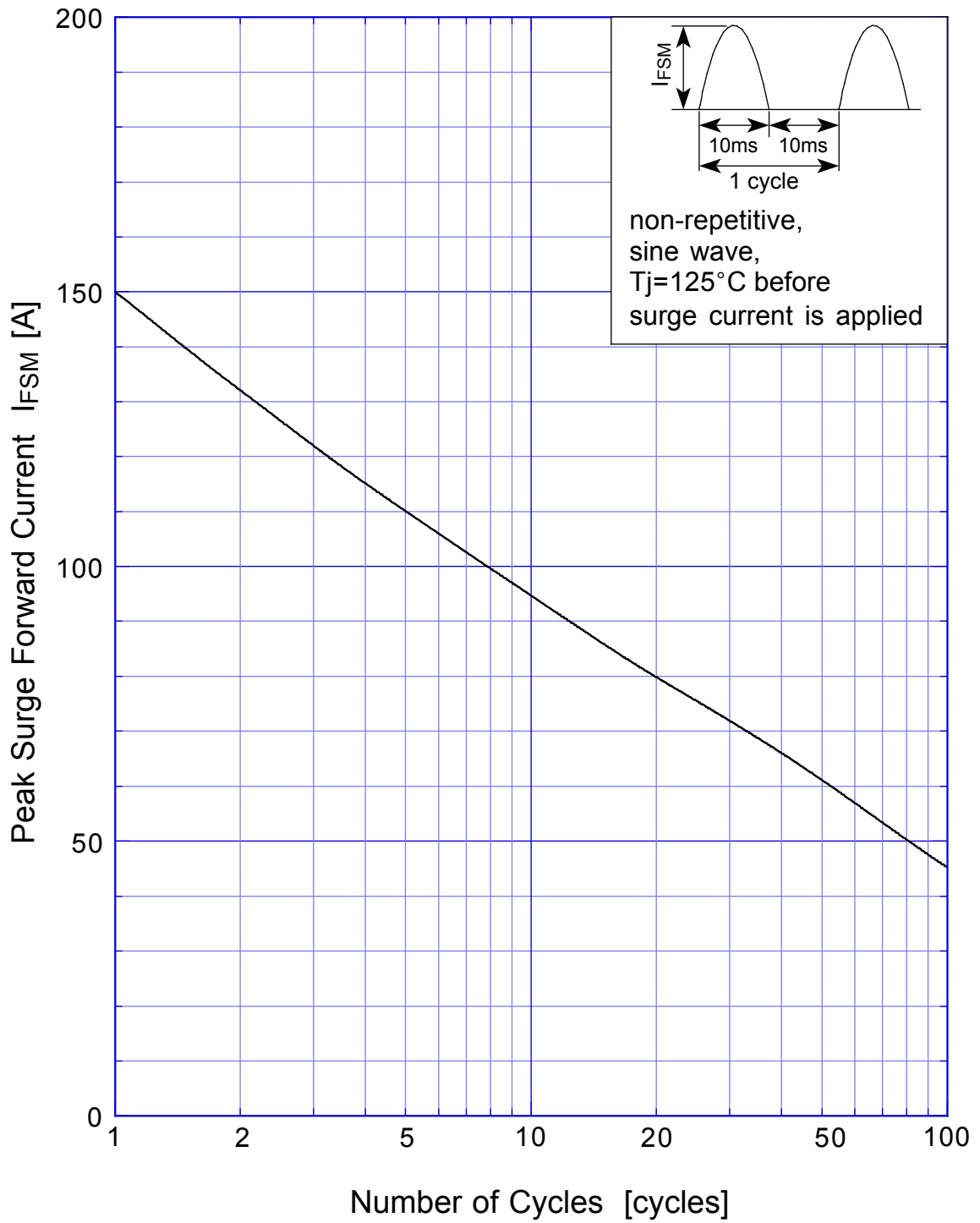

SBD Repetitive Surge Reverse Power Derating Curve

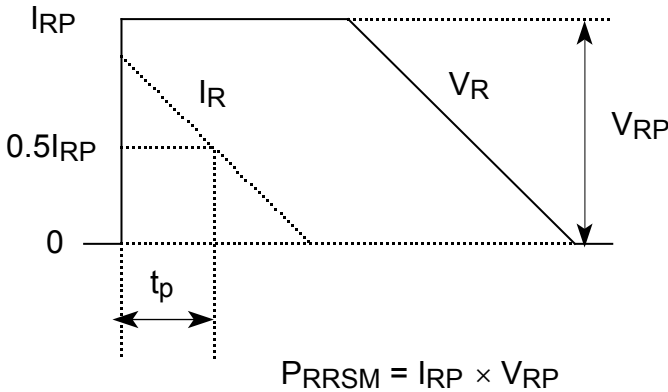
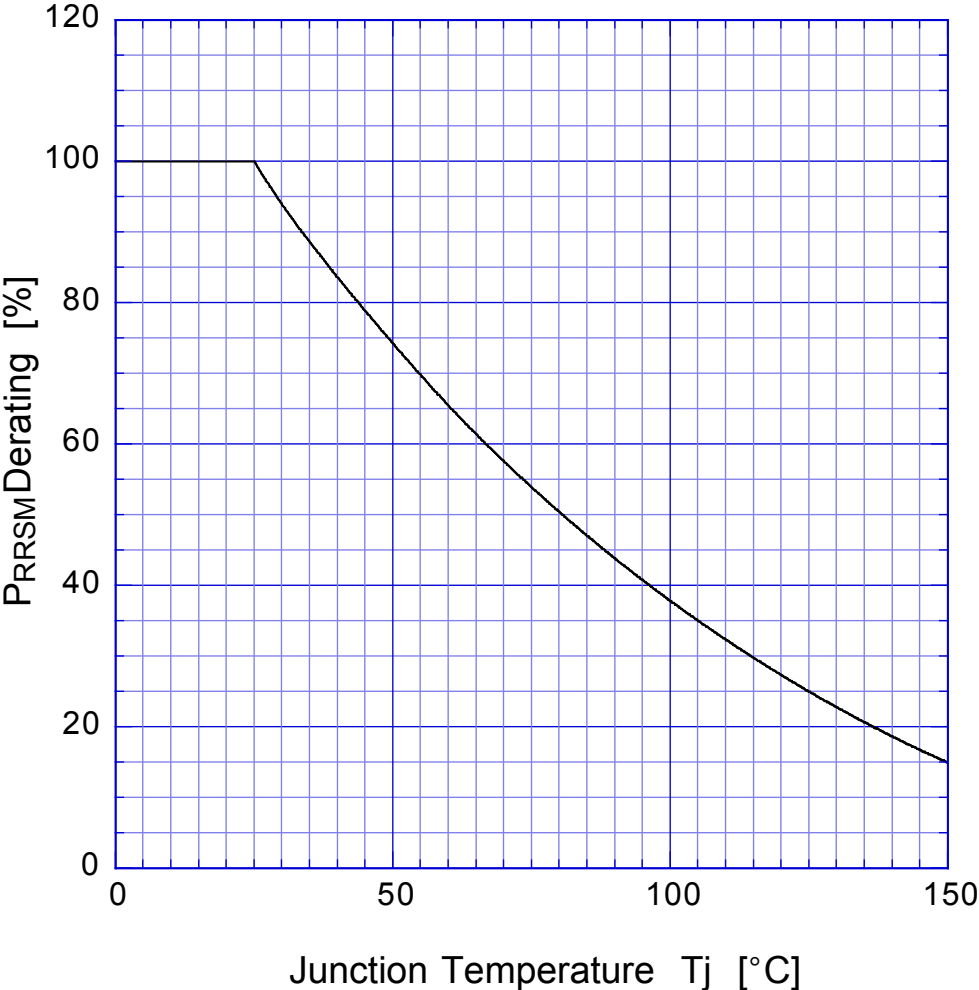

SBD

Repetitive Surge Reverse Power Capability

